

EV3 SEALED OIL TEMPERATURE GAUGE AND SENSOR INSTALLATION INSTRUCTIONS



ICON KEY



CAUTION



Tools may be required



Shown in picture

1 TEMPERATURE SENSOR INSTALLATION



Disconnect batteries. Do not reconnect battery power until system is fully configured to avoid risk of shock or fire.

2 Find a location where oil temperature can be measured such as an available port on the engine block, water pump, or coolant filtration head.

3 Check the thread size of the port being used. Use included adapter bushings, if required. Temperature sensor threads are 1/8" NPT.



Many Emission Control Devices are connected to temperature sensors or switches. Be careful not to disable these when installing a sensor.



If an adapter bushing is necessary, do not "bottom out" or close the gap when installing sensor into adapter bushings on units with tapered threads.

4 Thread the sensor into the adapter bushing (if used) finger tight, and then thread the sensor into the port finger tight. Next, tighten with a wrench approximately one-half turn. If leakage occurs at the sensor, tighten one-quarter turn at a time until leakage stops. If necessary, thread sealant such as Teflon tape may be used.



When using a torque wrench, tighten approximately 4.4 - 6.6 lb.-ft [6-9Nm] or slightly more if leakage occurs. Do not use the body of the sensor to tighten! Use only the hex and the correct wrench. Do not over tighten!

Temperature sensor with adapter bushing.

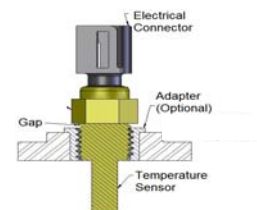

5 Connect the temperature sensor to the temperature sensor harness by pressing the connector into the slot.

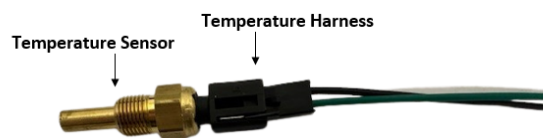

NOTE: If the sensor is in a location where it will be exposed to salt spray or road debris, fill the connector cavity with dielectric grease and wrap it tightly with electrical tape.

6 Route the pressure sensor harness' green and black wires to and through the firewall to the intended gauge location. Grommets usage is recommended.



Secure all wiring so that it does not interfere with moving parts or chafe on sharp edges. This may be accomplished by routing the wiring within the factory wire harness sheath, using wire ties and sheathing, and using appropriate grommets when passing through the firewall

Form No. IS262 (Rev. E 06/11/2024)

7

GAUGE INSTALLATION

Connect the 6-pin sealed connector to the back of the gauge (with the gauge near its final mounting location), then route the sensor portion of the harness towards the firewall and the red, orange, black and brown wires with cut ends towards the fuse panel or other area where the power, dimmer, ground and optional output relay connections will be made, leaving enough length at the 6-pin connector to allow you to remove the gauge from the mount without unplugging it from the gauge.



8



WIRING DIAGRAM

Wires to be connected as follows:

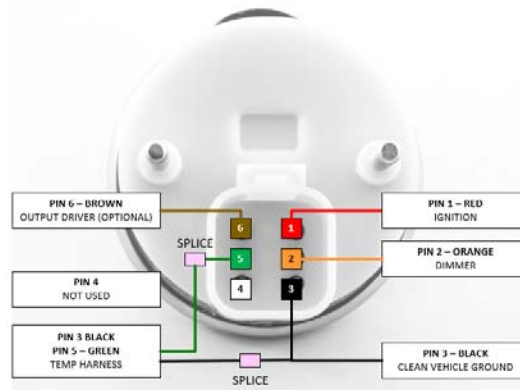

- **PIN 1 – Red:** [Ignition](#): Connect to one wire of the included fuse holder using the included crimp splice, and the other wire of the fuse holder connected to a circuit that switches on with the key switch. Install the included 1-amp fuse in the fuse holder. **Use only 1-amp fuses, higher amperage fuses may cause damage to the gauge or to the vehicle.**
- **PIN 2 – Orange:** [Dimmer](#): Connect to the factory gauge dimmer circuit by either tapping into the in-cab fuse block or by connecting directly to the wire running from the dimmer on the headlight switch. **NOTE:** The gauge backlighting will only illuminate if both the ignition AND the dimmer circuits are on.
- **PIN 3 - Black:** [Ground](#): Connect 1 black wire to a clean ground on the vehicle such as the battery negative terminal or a factory ground bolt. Splice the other black wire to the temperature sensor black wire.
- **PIN 5 – Green;** [Temperature Sensor](#): Splice to temperature sensor green wire.
- **PIN 6 – Brown:** [Programmable Output Driver](#): can switch devices that draw up to 1.3 Amps (60V) so a 1A (1 Amp) fuse should be used. **Devices** include customer supplied Relay Coils, Solenoids, Warning Buzzers, and Lamps. These devices are not included in gauge kits. The Output Driver activates these devices at a programmed level. When wiring to polarized devices always wire pin 6 to the negative side of the device.

For battery connection: Wire pin 6 to one side of the **device (see above)** with the other side of the device wired to a positive battery connection fused for no more than 1A.

For ignition connection: Wire pin 6 to one side of the **device (see above)** with the other side of the device wired to a connection that switches on with the key switch fused for no more than 1A

10

EV3 ATTRIBUTE PROGRAMMER INSTALLATION

Android - Open the Google Play Store application. In the Search box, type “Attribute Programmer”. Select the **EV3 Attribute Programmer** from ISSPRO and install it on your device.

iOS (Apple) - Open the App Store. In the Search box, type “Attribute Programmer”. Select the **EV3 Attribute Programmer** from ISSPRO and install it on your device.

ONCE INSTALLED - APP INSTRUCTIONS ARE LOCATED IN “EXTRAS”